

Presidential sofa
TECHNICAL FILE

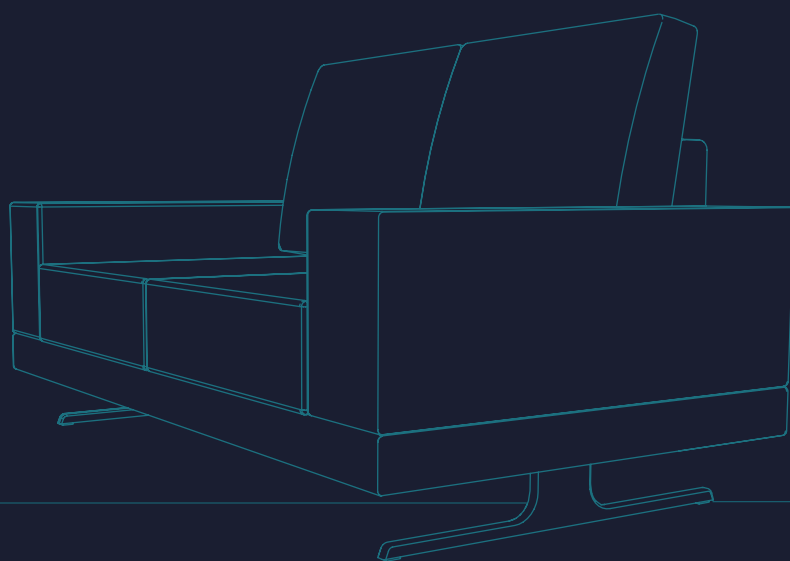

Thomas

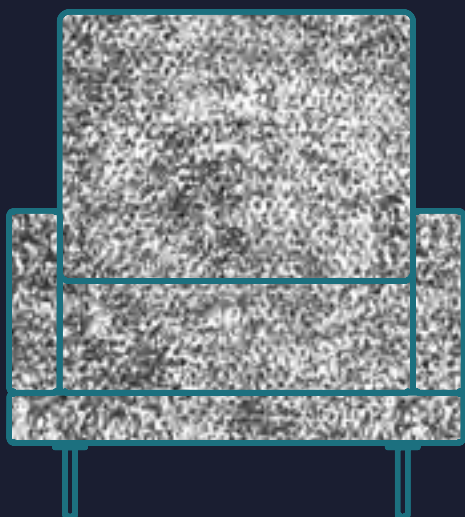

BOS
BARCELONA
— SINCE 1964 —

Materials, Finishes & Quality

- High quality wood structures from European beech.
- Seat and backrest with high quality molded foam fire-retardant, with high recovery capacity and good adapting performance.
 - Foam H.Q. Materialfilling
 - Ecological and resilient. Guaranteed to last with appropriate use.

Certifications :

Density kg / m³ (ISO 845). Compression strength (ISO 3386/1). Elongation (ISO 1798). Tensile strength (ISO 1798). Deformation remaining (ISO 1856 / A).

- Upholstery: Upholstered in different high quality materials:

1. Natural leather:

Hides are carefully selected among the best quality European rawhides. Pigmentation unifies the surface and masks natural hallmarks offering the optimum cutting yield and the pigmented finish also provides a soft feel and ensures extra protection against UVA and rub. The anti-stain finish combines warmth to the touch and easy maintenance.

Certifications:

Rub fastness : Dry (EN ISO 11640 / EN ISO 11641- Wet : EN ISO 11640 / EN ISO 11641). Light fastness (EN ISO 105 -B02). Tear propagation strength (EN 3377-1). Adhesion of finish (ISO 11644). Flammability (UNE EN ISO 1021-2)

2. Eco-Leather:

- a. Superior abrasion 300.000 cycles MARTINDALE
- b. Flame retardancy : EN ISO 1021 Part5 1 & 2

- Unique packaging in reticulated polyethylene foam. Triple layer of laminate polyethylene with hermetic bubbles 5x5 and density of 5400 bubbles/m². Corner protectors of high density reticulated polyethylene foam and cardboard box made to fit.

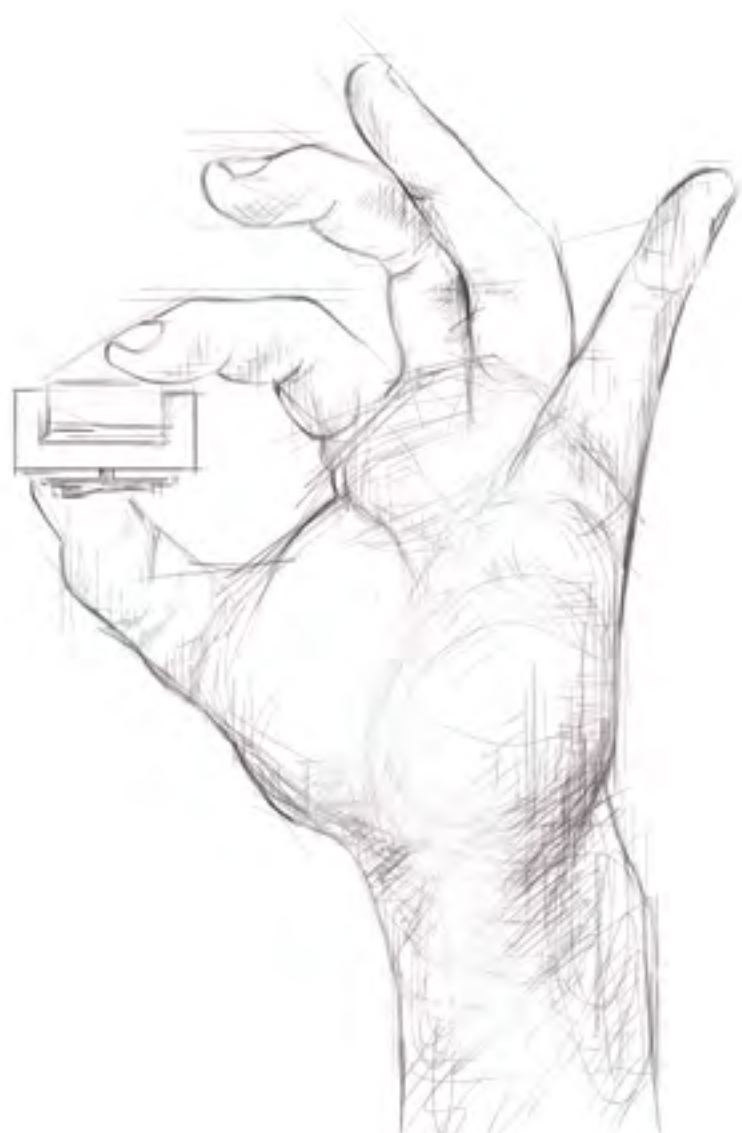

UNE-EN ISO
9001:2015

UNE-EN ISO
14001:2015

THOMAS SOFA

TECHNICAL PRESENTATION

Dimensions

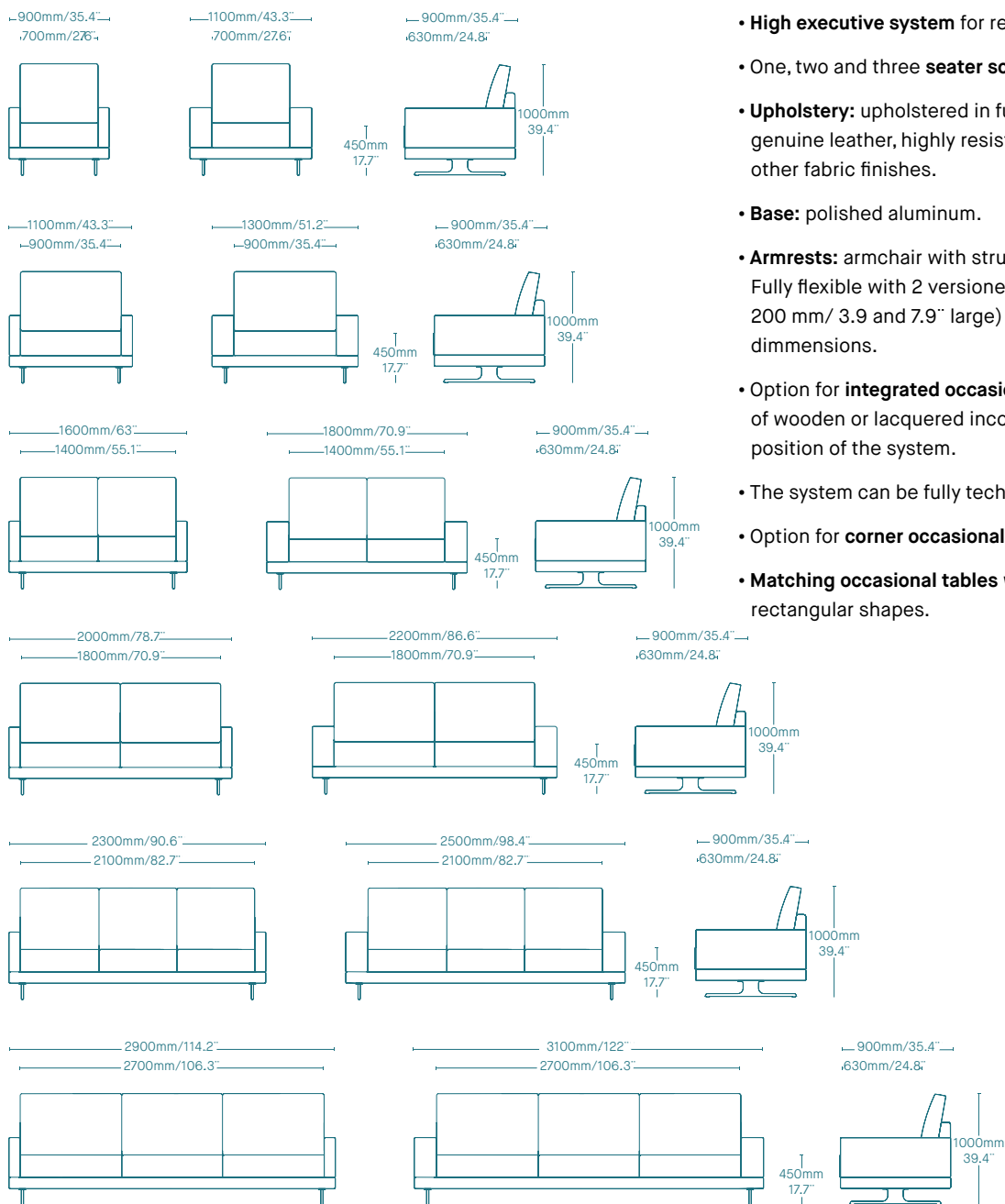

- **High executive system** for reception and lounge areas.
- One, two and three **seater sofas**.
- **Upholstery:** upholstered in full grain leather, natural genuine leather, highly resistant leather imitations or in other fabric finishes.
- **Base:** polished aluminum.
- **Armrests:** armchair with structural upholstery armrest. Fully flexible with 2 versions of arms (100 and 200 mm/ 3.9 and 7.9" large) and a large number of dimensions.
- Option for **integrated occasional tables**. Possibility of wooden or lacquered incorporated modules in any position of the system.
- The system can be fully technified.
- Option for **corner occasional tables and sofas**.
- **Matching occasional tables** with square, circular and rectangular shapes.

Occasional tables recommended

Aqua collection

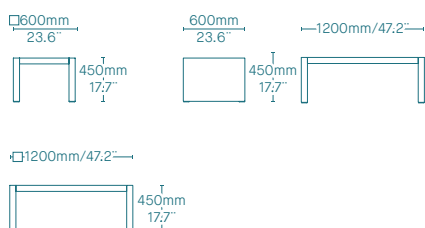

x64

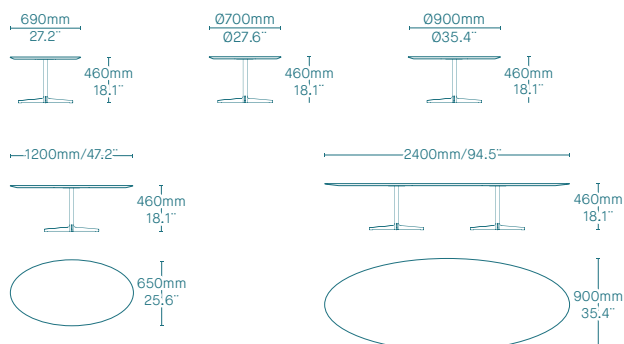

**THOMAS SOFA
MODELS**





Full Grain Leather - serie 900 - *Category Leather*

979	949	929
913	916	902
907	954	939
911	947	927
967	937	941
942	909	920
930	945	922
904	914	925
900	935	943
908	944	912
903		

Natural Leather - serie 100 - *Category Leather*

179	136	126
131	142	117
113	127	121
197	125	103

Eco leather - Valencia - *Category FAB1*

8032	1048	1049
1001	0002	9001
4001	1050	0035
2020	6019	0033
6012	2075	2062
5001	5069	0020
3001	3069	3067
4040	4002	4045
4043	4041	4003
		9035

Eco leather - Chronos - *Category FAB2*

0001	0002	0003
0008	0004	0007
0005	0006	0009
0013	0011	0010
0018	0019	0020

Eco leather - Polaris - *Category FAB2*

3393	3635	4712
3895	4714	3664
GZ96	2070	2938
3540	3663	3685
2774	2862	565

Fabric - Urban - Category FAB1

YN108	YN091	YN027
YN076	YN079	YN211
YN160	YN210	YN145
YN094	YN207	YN009

Fabric - X2 - Category FAB1

AK019	AK018	AK017
AK016	AK005	AK004
AK015	AK007	AK001
AK014	AK012	AK010

Fabric - Blazer - Category FAB2

CUZ28	CUZ47	CUZ2Q
CUZ58	CUZ2W	CUZ82
CUZ3D	CUZ86	CUZ31
CUZ18	CUZ63	CUZ90
CUZ1T	CUZ2S	CUZ21
CUZ1R	CUZ1V	CUZ2T
CUZ2Z	CUZ09	CUZ1Y
CUZ53	CUZ1L	CUZ1N
CUZ35	CUZ67	CUZ08

Fabric - Main Line Flax - Category FAB2

MLF20	MLF26	MLF16
MLF10	MLF24	MLF19
MLF17	MLF15	MLF14
MLF29	MLF33	MLF28

Fabric - Aquarius - Category FAB2

JA409	JA125	JA022
JA426	JA068	JA419
JA201	JA443	JA435
JA069	JA448	JA002

THOMAS SOFA FINISHES

Natural wood veneers

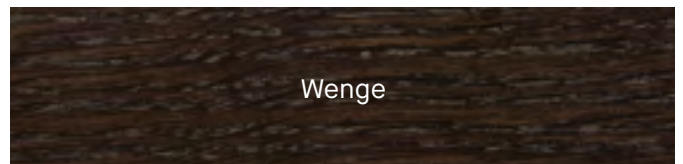
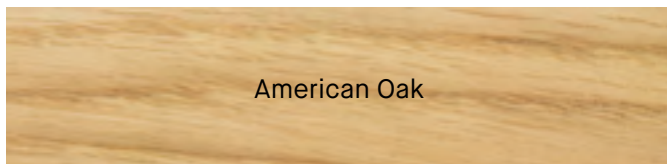
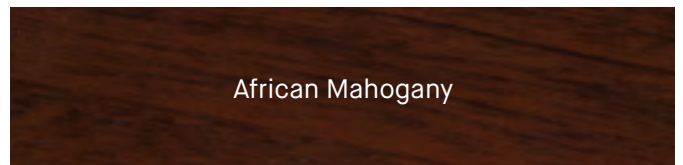
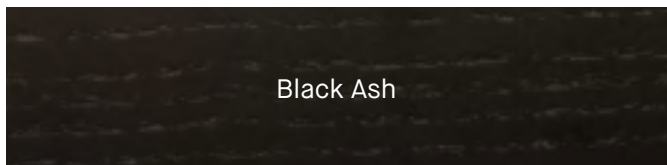
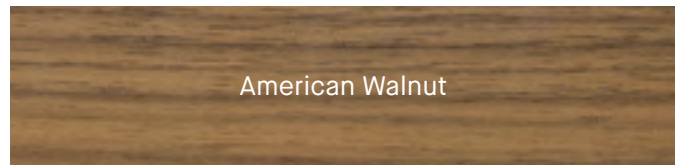
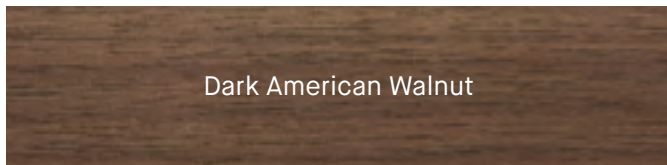
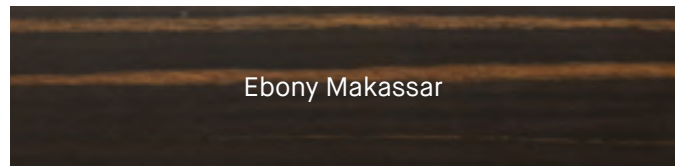
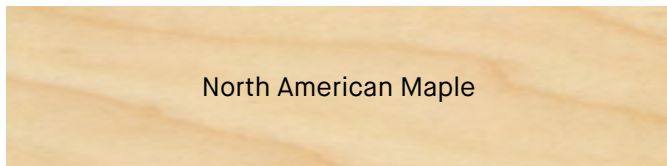

Lacquer finishes

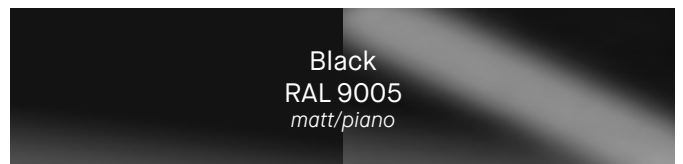
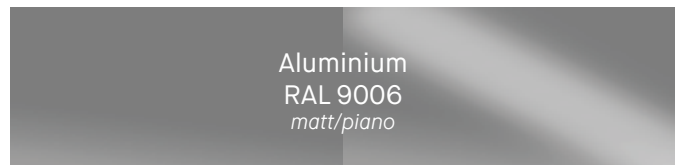





Diagonal 456
08006 Barcelona (Spain)

T +34 932 370 942
info@bos1964.com

 [bosbarcelona.com](https://www.bosbarcelona.com)

 Instagram
[@bosbarcelona](https://www.instagram.com/bosbarcelona)

 Facebook
[/bos1964](https://www.facebook.com/bos1964)

 LinkedIn
[Bos Barcelona](https://www.linkedin.com/company/Bos-Barcelona)

 Pinterest
[/bos1964](https://www.pinterest.com/bos1964)

 Youtube
[BOS Barcelona](https://www.youtube.com/BOS-Barcelona)