

MORE THAN A FURNITURE



outdoor & indoor life.

cridea collection

hub · pixel · move on · b-side · maya · rustle
dial · comodo · straight on

cridea

cridea.

*Embrace what Cridea is: take people out from the inside. To a new place...
Furniture More than a furniture, pieces with a transforming capacity that explore and foster interaction and relationships with new spaces and all kinds of people. Animals too. Moments for all seasons, weather conditions also. We say the **simplicity of the beautiful** because our heart and soul are reflected in its elegant lines and minimal gestures, in search of beauty through minimal gestures.*

*Fate vostro ciò che Cridea è: condurre le persone da dentro a fuori.
A luoghi che prima non erano tali...
Mobili Più che mobili, elementi che si trasformano, che esplorano e creano relazioni con nuovi spazi, persone ed animali. Momenti per tutte le stagioni e condizioni climatiche.
Raccontiamo **la semplicità del bello** perché la nostra anima e la nostra energia stanno qui, nella ricerca della bellezza attraverso piccoli gesti.*

Move. Stop. Move on is made up of three different sized modules, either joined or separated to create everyday settings. Its comfortable volume and smooth curves make you feel at home wherever you are.

Spostarsi. Fermarsi. Move on è composto da tre moduli di diversa dimensione che si uniscono o separano per creare scenari di vita quotidiana. Un volume confortevole e curve sinuose che rendono casa il posto in cui si trova.



move on sofa 150 // almondline.

move on.



the beauty of simplicity.



more than a furniture.



move on armchair 65 // greenyellow
move on armchair 80 // move on sofa 160 // tofu.

Sit inside to look outside and feel like going out. Get up, go outside and sit down, also on move on. This family is made up of three different sized modules that come together or separately to inspire everyday moments under a roof or under the sky.

~~Always outdoors. Always indoors.~~
Always everywhere.

Sedersi all'interno per osservare l'esterno e provare il desiderio di uscire. Alzarsi, uscire e sedersi, anche in move on. Questo gruppo è formato da tre moduli di diverse dimensioni che si uniscono e si separano, per progettare momenti di vita quotidiana sotto un soffitto come sotto il cielo.

*Sempre all'aperto. Sempre al chiuso.
Sempre ovunque.*

move on.

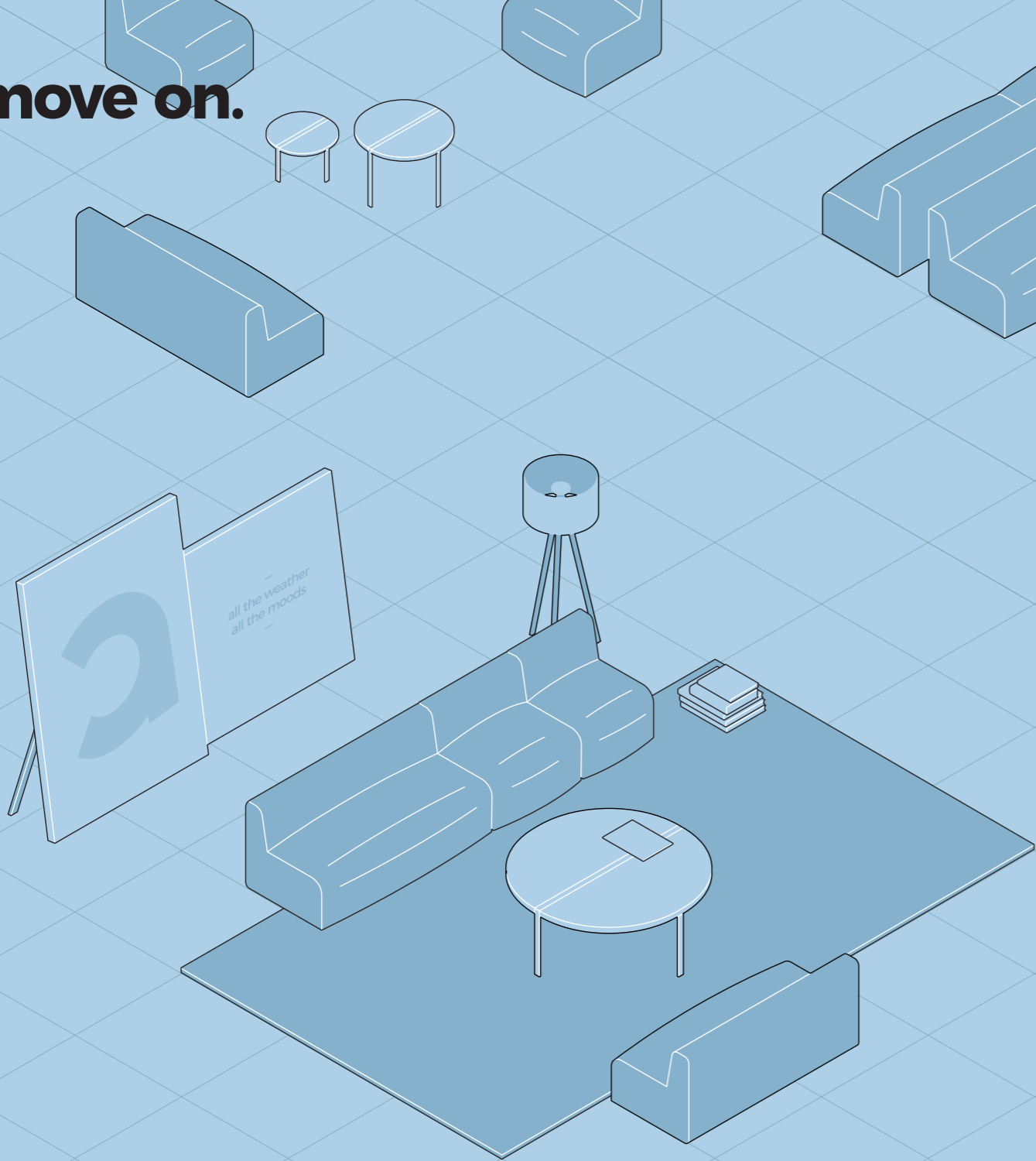

by Jorge Herrera Studio.

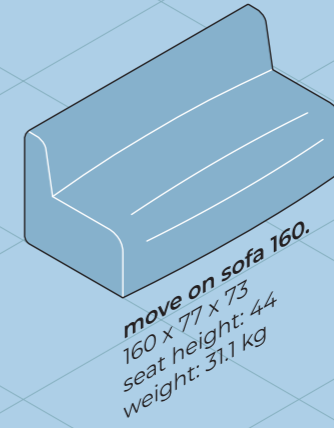

move on sofa 160.
160 x 77 x 73
seat height: 44
weight: 31.1 kg

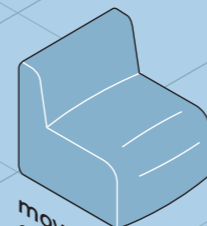

move on armchair 65.
65 x 77 x 73
seat height: 44
weight: 13 kg

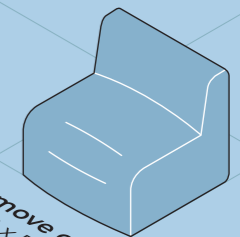

move on armchair 80.
80 x 77 x 73
seat height: 44
weight: 16 kg

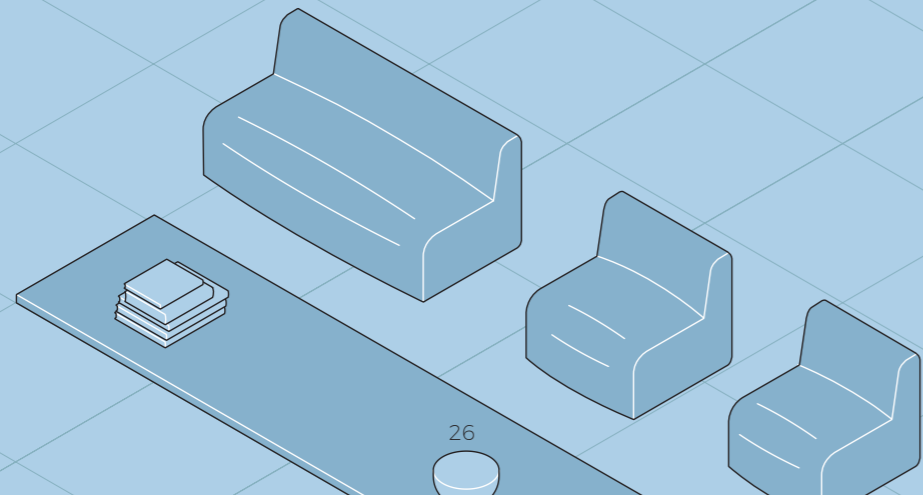



finishes.

**DOTS TAKEN FROM BRIGHT
FIRMAMENTS, COLOR
GRADIENTS INSPIRED
BY SOME OF THE MOST
BEAUTIFUL PLACES ON
THE PLANET, PERFECT
MATTE COLORS AND MANY
TEXTURES.**

**PUNTI PRESI DA CIELI
LUMINOSI, SFUMATURE DI
COLORI ISPIRATE AD ALCUNI
TRA I LUOGHI PIÙ BELLI DEL
PIANETA, COLORI OPACHI
PERFETTI E TUTTE LE
TRAME.**

color.

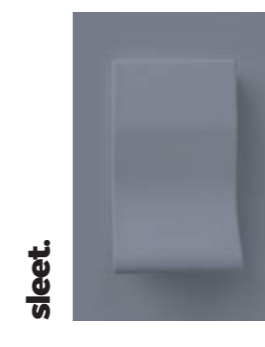
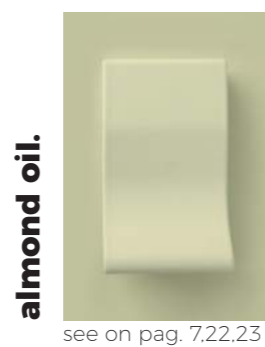
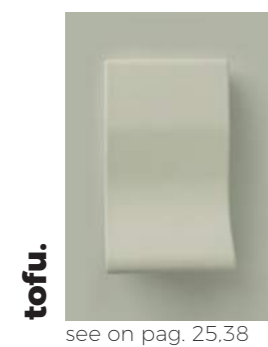
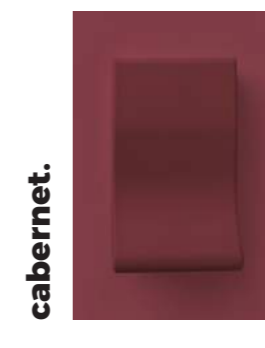
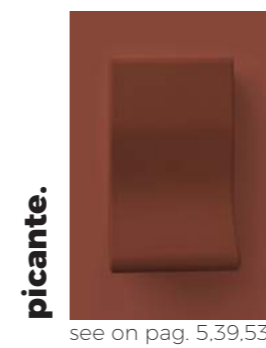
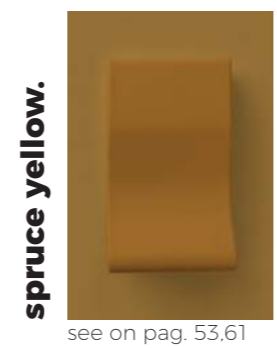

Look carefully at these 27 colors. This catalogue is paper, applied to the surface of the different supports the colors can change, but only slightly.

Guarda con attenzione questi 27 colori. Il catalogo è cartaceo, applicato sulle diverse superfici può cambiare leggermente.

dots.

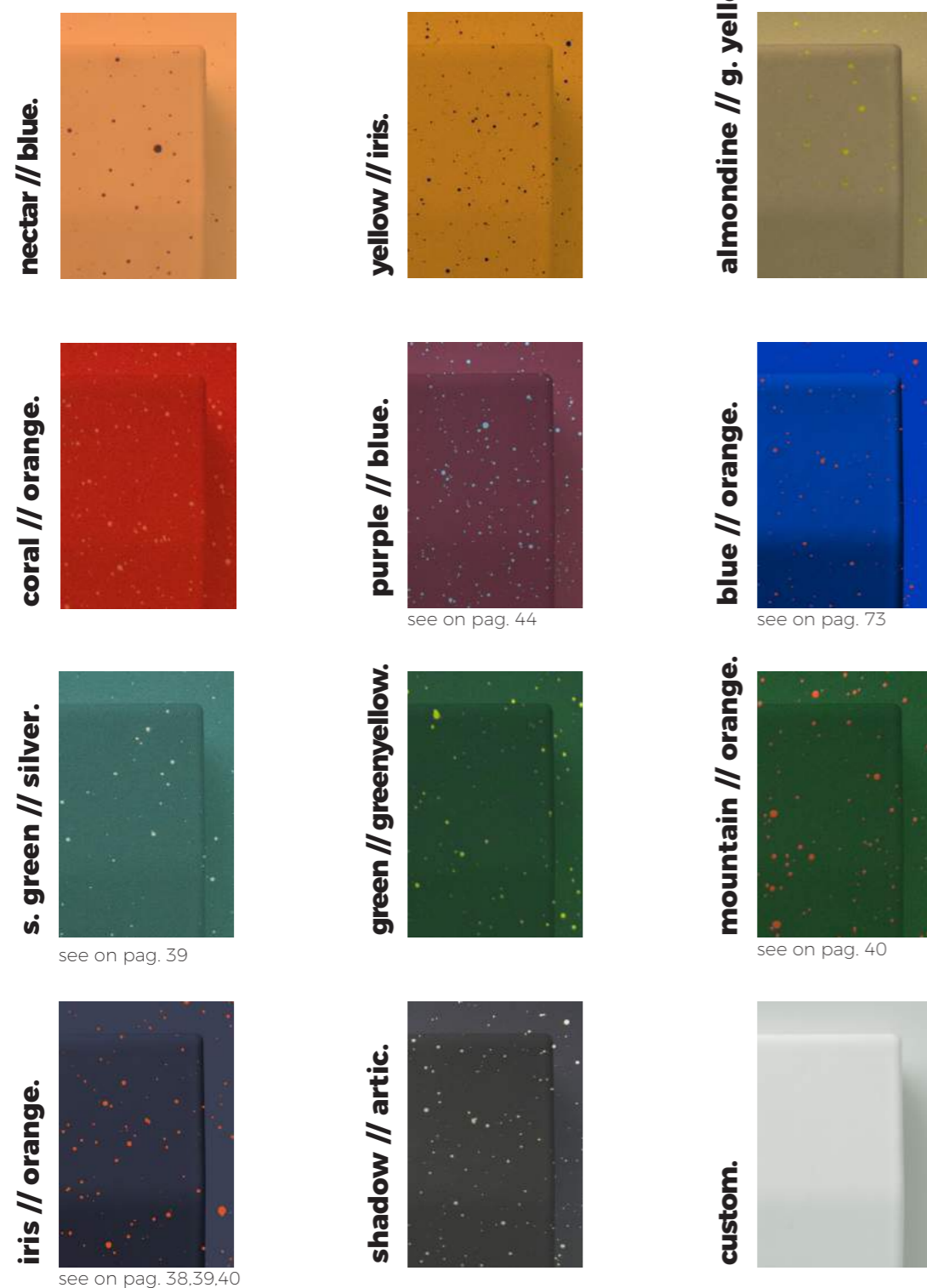

Although we follow a process that seeks to standardise painting, it is not the same if Paolo or Andrea is painting. The dot finish is done by hand. Small differences – in the points – that give uniqueness.

Nonostante applichiamo un processo che mira alla standardizzazione della verniciatura, non è lo stesso se a dipingere è Paolo o Andrea. Il dots finale viene realizzato a mano. Piccole differenze - di punti- che attribuiscono originalità.

gradient.

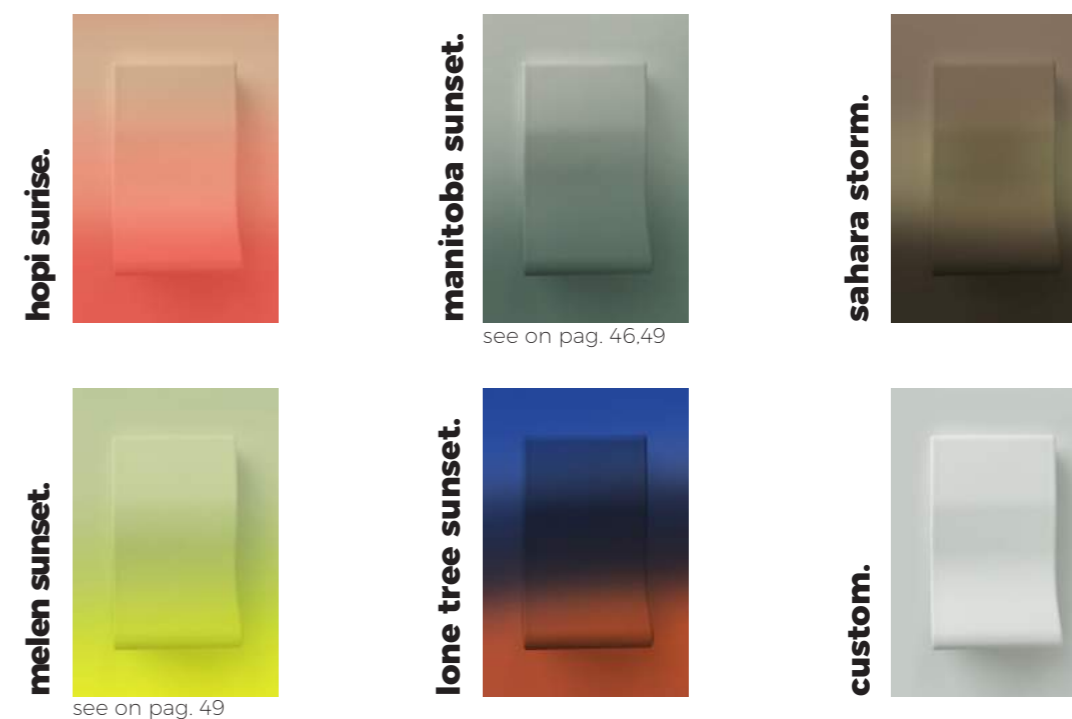

The light of our favourite places, where the gradients come from, is never the same, so these finishes may vary slightly, depending on the moment and according to the painter.

La luce dei nostri spazi preferiti, da cui hanno origine le sfumature, non è mai la stessa, per questo le finiture possono differire leggermente l'una dall'altra in base al momento e all'operatore.

texture.

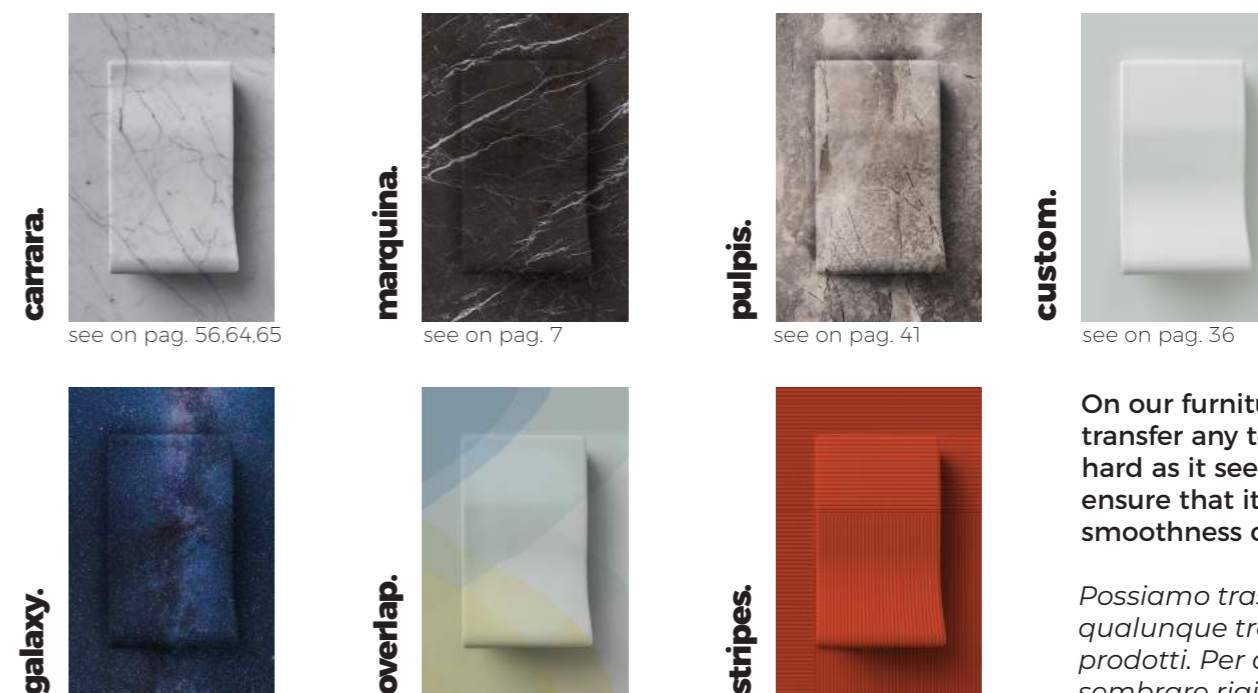

On our furniture we can transfer any texture. As hard as it seems we will ensure that it has the smoothness of all finishes.

Possiamo trasferire qualunque trama sui nostri prodotti. Per quanto possa sembrare rigida faremo in modo di conferirle la morbidezza di tutte le altre finiture.

the material.

The pieces of Cridea feel, stirs our emotions. Its 27 eye-catching colors move us. Its matte finish hints at the softness of its touch and feel: the absolute softness of the protective skin. Sometimes we play and the texture does not correspond to the outer look, we keep playing with the essentialism of a hard and firm look, which under the weight of use, is soft and comfortable. It is the material. The material is everything and almost eternal. Our products are made to last with a long life cycle. Live what you want in them.

I pezzi di Cridea provano e generano emozioni. I suoi 27 accattivanti colori entusiasmano. La sua finitura opaca anticipa la morbidezza del tocco: la morbidezza assoluta dello strato protettivo. A volte giochiamo, e la trama non corrisponde all'aspetto esterno, continuiamo a giocare con l'essentialismo di un aspetto duro e deciso, che sotto il peso dell'uso, è anche morbido e confortevole. È il materiale. Il materiale è tutto ed è quasi eterno. I nostri prodotti sono concepiti per durare una vita intera. Vivi tutto ciò che vuoi con loro.



Easily-recyclable parts. What you don't throw away, doesn't need recycling. Our products are made for use and last ages without deterioration. We use —high quality— materials and are committed to the environment. It's no joke. Every action leaves an indelible mark on the planet, but that footprint can be reduced with the use of resistant materials. With the durability of our products we minimise our footprint, with the possibility of regenerating them, we reduce the negative impact. Furniture that lasts for the good of the planet.

Prodotti facilmente riciclabili. Non c'è bisogno di riciclare qualcosa che non si getta via. I nostri prodotti sono fatti per essere usati e durare anni senza rovinarsi. Usiamo materiali —di alta qualità— e pensiamo all'ambiente. Non è uno scherzo. Ogni opera lascia un segno indelebile sul pianeta, ma questa impronta può ridursi con l'uso di materiali resistenti. La durabilità dei nostri prodotti minimizza questo nostro segno, e con la possibilità di rigenerarli si riduce ulteriormente l'impatto negativo. Mobili che durano per il bene del pianeta.



Furniture that adapts to any time or place. Imagine being able to cheat doing a puzzle: cutting, resizing, widening or lengthening it. Our products are highly customizable and adapt to any space or environment — all you have to do is enjoy them. Friendly furniture.

Prodotti che si adattano a ogni tempo e luogo. Immaginate di poter imbrogliare facendo un puzzle: tagliarlo, rimodellarlo, allungarlo o allargarlo. I nostri prodotti sono personalizzabili e si adattano a ogni spazio e ambiente — non vi rimane che goderveli. Arredamento amico.



Pieces of furniture covered in an outer skin, that's what we call it. It's a soft polyurethane material that covers the muscles and skeletons that are blocks of flexible foam specially selected and ingeniously taken advantage of as each little part gives life to an almost eternal piece of furniture. At a glance you can appreciate their toughness. Up close you see a smooth, compact, uniform exterior. Closed cells that cannot be pierced. Ideal for all climates and uses. Tap, squeeze or step on them. They're soft. After adapting to your shape they return to their original form. Spill something on them and you'll find they're easy to clean.

Prodotti ricoperti da una pelle esterna, ecco come li chiamiamo. Si tratta di un materiale poliuretano che ricopre la muscolatura e lo scheletro, blocchi di schiuma flessibile appositamente selezionati e sfruttati sapientemente perché ogni piccola parte può dare vita ad un prodotto quasi eterno. Ad un primo sguardo se ne può apprezzare la resistenza. Più da vicino si vede una parte esterna liscia, compatta, uniforme. Celle chiuse che non possono essere permeate. Ideale per tutti i climi e usi. Tocca, premi o saltaci sopra. Sono morbidi. Dopo essersi adattati alla tua figura tornano alla loro forma originale. Versaci sopra qualcosa e vedrai quanto siano semplici da pulire.

Edition.

July 2020. designed, curated and vacuum-packed during covid-19 pandemic.
Luglio 2020. Disegnato, curato e impacchettato sottovuoto durante la pandemia di covid-19.

Art Direction.

Jorge Herrera Studio.

Design.

Jorge Herrera Studio.

Still Life Photography.

Fabrizia Aparasi.

Martín Pérez.

Jorge Herrera Studio.

CGI.

Kaiserbold.

Danni.

Copy.

Lidia Caro Leal.

Fermín Palacios.

Acknowledgements

Ana, the pastry chef.

Luisa & Francesco Combi, the big garden.

Printing

Impresum.

Oikos Paper 50% pure environmentally friendly certified FSC® fibres and 50% recycled fibres.

Oikos è una carta ecologica certificata FSC Mixed Sources, composta per il 50% da fibre riciclate e per il 50% da fibre di pura cellulosa.

Headquarters

Viale Lombardia 16/20
20841 Carate B.za (MB)

Italy

Tel. +39 0362 804161

Registered Office

Via Sirtori, 39
20838 Renate B.za (MB)

Italy

Tel. +39 0362 924984

Cridea reserves the right to introduce modifications with a reason.

We will not notify you in advance, but you may contact us.

Cridea si riserva il diritto di apportare modifiche con ragion d'essere ai modelli.

Non lo notificheremo prima, ma potrete chiedercelo.

hello@cridea.it
www.cridea.it

...It 's raining, so what?

Earth, wind, air and fire, ultraviolet radiation too.
Designed to resist the force of all the elements.
Furniture for all settings and all seasons.

