

Top management sofa
TECHNICAL FILE

Hugo

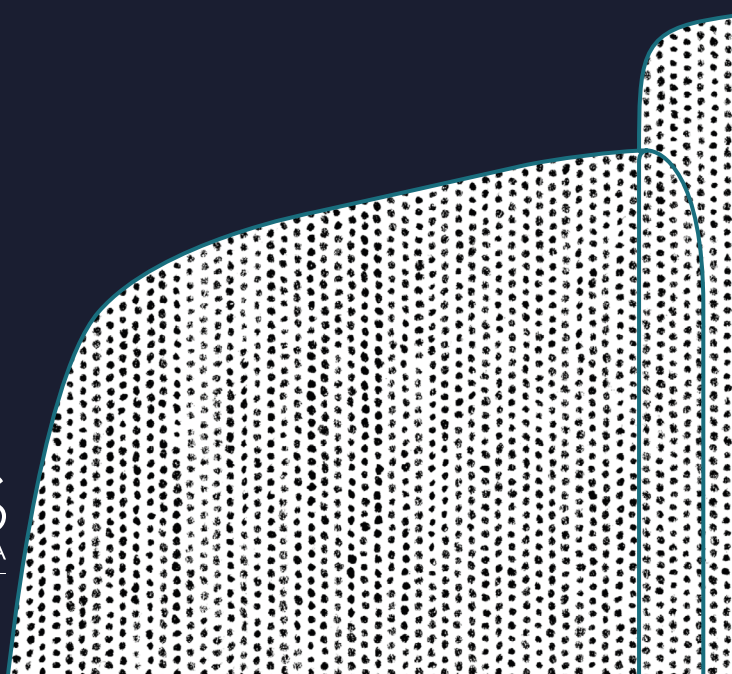

BOS
BARCELONA
— SINCE 1964 —



Materials, Finishes & Quality

- High quality wood structures from European beech.
- Seat and backrest with high quality molded foam fire-retardant, with high recovery capacity and good adapting performance.
 - Foam H.Q. Materialfilling
 - Ecological and resilient. Guaranteed to last with appropriate use.

Certifications :

Density kg / m³ (ISO 845). Compression strength (ISO 3386/1). Elongation (ISO 1798). Tensile strength (ISO 1798). Deformation remaining (ISO 1856 / A).

- Upholstery: Upholstered in different high quality materials:

1. Natural leather:

Hides are carefully selected among the best quality European rawhides. Pigmentation unifies the surface and masks natural hallmarks offering the optimum cutting yield and the pigmented finish also provides a soft feel and ensures extra protection against UVA and rub. The anti-stain finish combines warmth to the touch and easy maintenance.

Certifications:

Rub fastness : Dry (EN ISO 11640 / EN ISO 11641- Wet : EN ISO 11640 / EN ISO 11641). Light fastness (EN ISO 105 -B02). Tear propagation strength (EN 3377-1). Adhesion of finish (ISO 11644). Flammability (UNE EN ISO 1021-2)

2. Tech Leather:

a. Superior abrasion 300.000 cycles MARTINDALE

b. Flame retardancy : EN ISO 1021 Part5 1 & 2

- Unique packaging in reticulated polyethylene foam. Triple layer of laminate polyethylene with hermetic bubbles 5x5 and density of 5400 bubbles/m². Corner protectors of high density reticulated polyethylene foam and cardboard box made to fit.

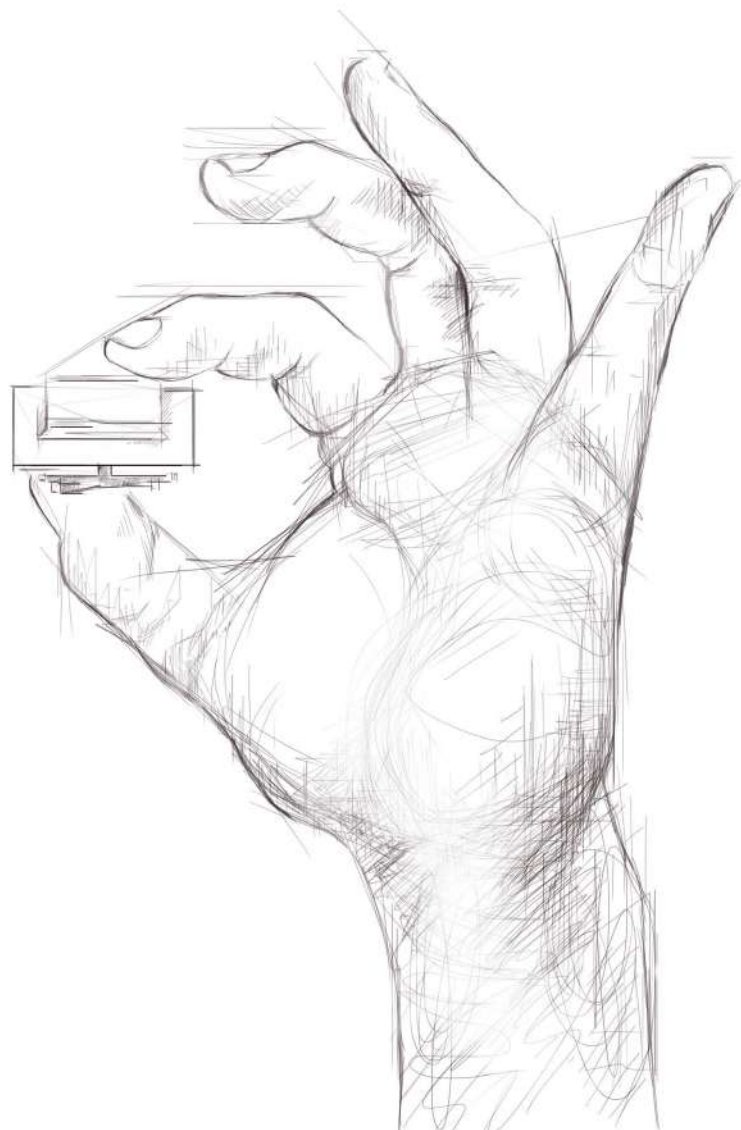

UNE-EN ISO
9001:2015

UNE-EN ISO
14001:2015

HUGO SOFA

TECHNICAL PRESENTATION

Dimensions in mm

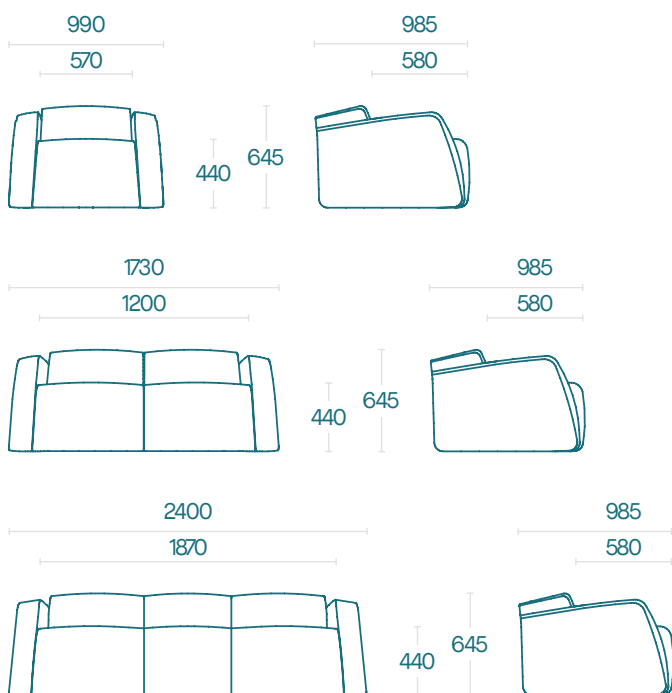

- One, two and three **seater sofas**
- **Upholstery:** upholstered in full grain leather, natural genuine leather, highly resistant leather imitations or in other fabric finishes.
- **Armrests:** armchair with structural armrests.
- **Matching coffee tables** with square and rectangular shapes

Occasional tables recommended

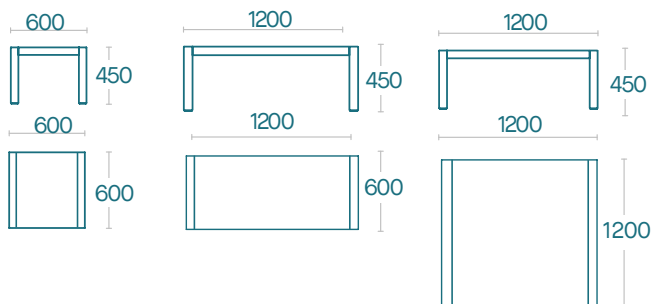

**HUGO SOFA
MODELS**





HUGO SOFA FINISHES

leather

Full Grain Leather - S900

902	937	920
904	942	924
911	947	927
913	950	934
915	903	940
923	908	945
925	912	949
928	914	951

Natural Leather - S100

4001	0020	0020
8032	2020	2020
1048	6012	6012
1049	6019	6019
1001	2075	2075
0002	3067	3067
1050	2062	2062
0035	3001	3001
0033	3069	3069

ECO - Leather - Valencia

147	103	131
109	179	139
121	136	142
145	126	115
		125

Blazer collection



Main Line Flax collection



HUGO SOFA FINISHES

Wood

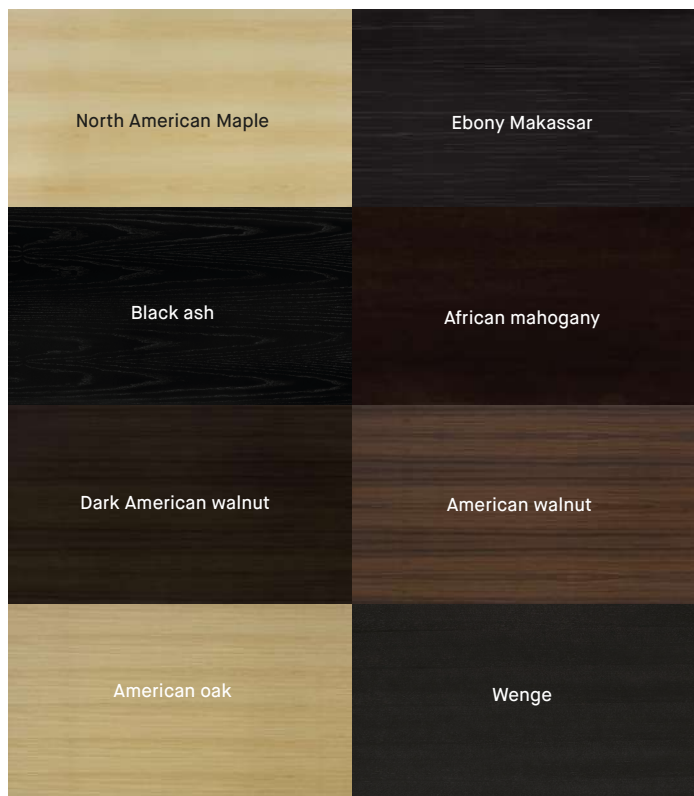

Lacquer (matt / piano)

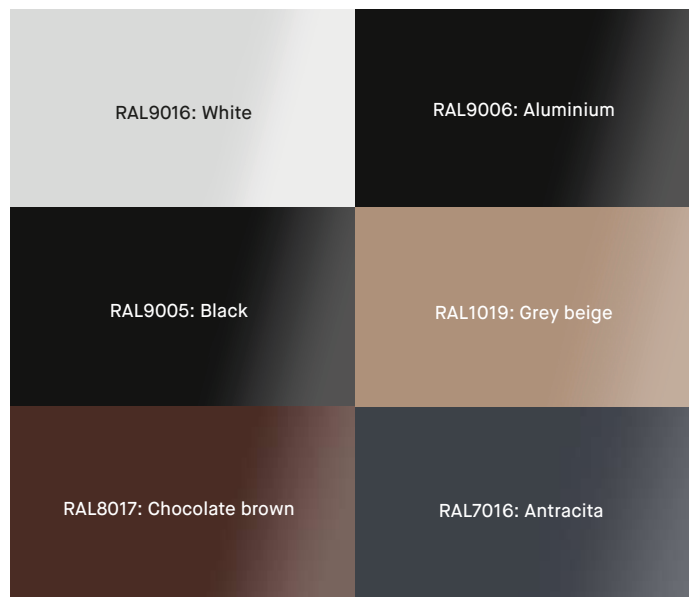



Headquarters
Av. Diagonal 456
08006 Barcelona, Spain

Sales enquiries
info@bosbarcelona.com
T. +34 932 370 942

www.bosbarcelona.com